

# IEEE/AIAA ITEC+EATS Student Design Competition

## Announcement

The IEEE/AIAA Transportation Electrification Conference and Electric Aircraft Technologies Symposium (ITEC+EATS) invites you to participate in the 2025 Student Design Challenge.

## Background

At the 2024 AIAA Science and Technology Forum and Exposition (AIAA SciTech Forum) in January 2024, Elysian Aircraft launched their concept for a 90-seater full<sup>1</sup> electric regional aircraft, with a turbogenerator for reserves/emergency scenarios, the E9X concept [ref.1]. The Elysian E9X aircraft can travel up to 800 kilometers (500 miles) on a single charge, with 2035+ expected EIS.

## Challenge:

The aim of the 2025 Student Design Challenge is to design the high voltage/high-power distribution system for a regional (90 passenger) fully electric aircraft, with a kerosene-based turbogenerator to cover reserves. The high-voltage electrical system must transmit power from the batteries to eight electrically-driven propellers, while the kerosene-based reserve energy system must generate electricity to charge the batteries or power the electric motors during diversion, loiter, or contingency scenarios. In the design of this architecture, you must also consider non-propulsive power (used e.g. for thermal management of the electrical powertrain) as well as the different voltage levels required for on-board electrical systems (on low and medium voltage). The powertrain architecture must be designed to meet safety requirements specified in the regulations, to ensure the aircraft can safely land in case a failure occurs.

## Eligibility

More than one design may be submitted from students at any one school. Teams can consist of the following:

- Undergraduate students
- Graduate students
- Combined Undergrad and Graduate students

## Schedule

- January 12, 2024 – Submission opens
- April 15, 2025 – Submission deadline
- May 15, 2025 – Winner announcement
- June 18-20, 2025 – ITEC+EATS2025

Website for submissions: <https://zfrmz.com/bKcRPJgAF9nvaHYcQEvm>

## Prize

Monetary Award: 750\$ 1st prize, 500\$ 2nd prize, 250\$ 3rd prize

Sponsored by: Elysian Aircraft  E L Y S I A N

---

<sup>1</sup> Fully electric in normal operations. With the range extender for reserves, it could be considered a hybrid-electric aircraft.

## Design Specification

### General Requirements

- *Capable of taking off and landing from runways (asphalt & concrete)*
- Capable of flight in known icing conditions
- Meets applicable certification rules in FAR-25. In particular, meet the system safety requirements as specified in 14 CFR Part 25.1309 / EASA CS-25.1309:
  - The failure of a single component in the powertrain may not lead to catastrophic failure of the aircraft
  - The chance of (cascading) failure of multiple components leading to a catastrophic failure of the aircraft may not exceed a probability of  $10^{-9}$  times per flight hour.
- Use of technologies that will be in service by 2035+ and document battery energy and power density assumptions based on reasonable technology trends.
- Provide systems and power propulsion architecture that will enable high voltage/ high power flight.
- Fulfil all safety considerations and high voltage issues management.

### Mission Requirements

Consider a typical aircraft with the following specifications:

- Payload: 90 PAX; 9000 kg
- *MTOM: 76000kg;*
- *OEM: 23500kg excluding powertrain group\*;*
- *Fuel for reserves (incl. fuel system): 1000kg*
- *Aircraft characteristics: Length: 33m; Span: 42m; Fuselage diameter: 3m; Wing area: 150m<sup>2</sup>*
- Total installed shaft power of 12 MW (max continuous) at the propeller;
- 250kW off take at 270V DC (environmental control systems, thermal management systems)
- 25kW off take at 28V DC (avionics, cabin entertainment power supply)
- 8 electric-motors, four per wing
- Target mass of powertrain group\*<sup>2</sup>: 42500 kg (any more will reduce the payload capability)
- Propeller rotational speed: 1200 rpm
- *Target: 800 km design range mission*
- *Nominal cruise altitude: 7500m*
- *9000m ceiling*
- *Minimum cruise speed of 500km/h.*
- *Target cruise speed: 550 km/h or greater*
- *Speed at take-off: 300km/h;*
- *Maximum takeoff and landing field lengths of 2000m over a 15m obstacle to a runway with dry pavement (sea level ISA + 15K day).*

### Reporting and Design Data Requirements

Please provide the following elements:

---

<sup>2</sup> The powertrain group includes electric motors, generator, battery, power electronics, gas turbine and accessories, gearbox if applicable, cooling systems, and all elements of the high-voltage power transmission (cables, circuit breakers, buses, etc.). Excludes propellers and fuel.

- Given the above mission profile, one or more schematic drawings showing the general architecture of the power distribution for propulsion, from the energy source to the loads (e.g. electric motors), through power converters, electrical wiring system, and protection devices.
- A sensitivity study, to define the network voltage that is optimal, according to your calculation, and the impact on all components of the power chain, particularly the mass. Please detail how the voltage affects the mass of wiring cables and connectors, the cables and insulation thickness and mass, the choice of switching components in a converter and the converter topology. You should also discuss the voltage waveform (DC, AC, and frequency, PWM and frequency) in the power chain.
- Make sure to also consider non-propulsive power and the respective architectures necessary for these components.
- Description of battery system division into packs/modules and their usage for the different voltage levels
- A safety analysis, which describes the failures that are considered in your design, how the network design is fault-tolerant with respect to these failures, and how fault propagation is mitigated.
- Assumptions on at least specific fuel consumption/efficiency, thrust/power and weight should be specified.
- Estimate equivalent range according to Ref [3]

Below are further details, which should be included in your study.

- Thermal management: account for the thermal management power and mass budget considering the operating temperature of the high-voltage powertrain and required cooling/heating under different flight conditions.
- Issues linked to high voltage: for the phenomenon listed below, indicate how you intend to mitigate them: the physical laws and/or design rules that you are using, whether protection components are needed in the electrical installation, etc... Keep in mind that some of the phenomena may be critical, depending on the voltage kind (DC, AC / PWM).
- Partial discharges.
- Parallel arc (short-circuit between two conductors at a different potential), serial arc (electrical arc occurring on a line, for instance on a connector or terminal block);
- Electrical shock to persons due to high voltage.
- Overcurrent due to short-circuit.
- Assumptions regarding individual component reliability, in terms of probability of failure per flight hour.
- Document system efficiency including at least the efficiency of the batteries, wires, power electronic controllers, thermal management system, connectors, motors, and propellers to calculate a total propulsive efficiency.
- Document electric propulsion system weight

### Submission and Ranking

The Proposal shall be a written report in English of 30 pages maximum. It is not mandatory to have a hardware demonstrator. A video with a maximum of 5-minute duration can be submitted with the proposal. Every proposal will be evaluated by a jury panel, according to the following ranking:

- Originality (25 points)

- Technical content (25 points)
- Feasibility (25 points)
- Report quality and clarity (25 points).

### Copyright

All submissions to the competition shall be the original work of the team members. Authors retain copyright ownership of all written works submitted to the competition. By virtue of participating in the competition, team members and report authors grant AIAA and IEEE non-exclusive license to reproduce submissions, in completely or in part, for all of AIAA's and IEEE current and future print and electronic uses. Appropriate acknowledgment will accompany any reuse of materials.

### Conflict of Interest

It should be noted that it should be considered a conflict of interest for a design professor to write or assist in writing RFPs and/or judging proposals submitted if he/she would have students participating in, or that can be expected to participate in those competitions. A design professor with such a conflict must refrain from participating in the development of such competition RFPs and/or judging any proposals submitted in such competitions.

### Suggested References

1. Rob E. Wolleswinkel, Reynard de Vries, Maurice Hoogreef and Roelof Vos. "A New Perspective on Battery-Electric Aviation, Part I: Reassessment of Achievable Range," AIAA 2024-1489. AIAA SCITECH 2024 Forum. January 2024. - <https://arc.aiaa.org/doi/10.2514/6.2024-1489>
2. Reynard de Vries, Rob E. Wolleswinkel, Maurice Hoogreef and Roelof Vos. "A New Perspective on Battery-Electric Aviation, Part II: Conceptual Design of a 90-Seater," AIAA 2024-1490. AIAA SCITECH 2024 Forum. January 2024. - <https://arc.aiaa.org/doi/10.2514/6.2024-1489>
3. Reynard de Vries, Maurice F. M. Hoogreef, and Roelof Vos, "Range Equation for Hybrid-Electric Aircraft with Constant Power Split", Journal of Aircraft 2020 57:3, 552-557
4. EASA CS-25 / 14 CFR Part 25
5. <https://ieeexplore.ieee.org/stamp/stamp.jsp?tp=&arnumber=9814008>

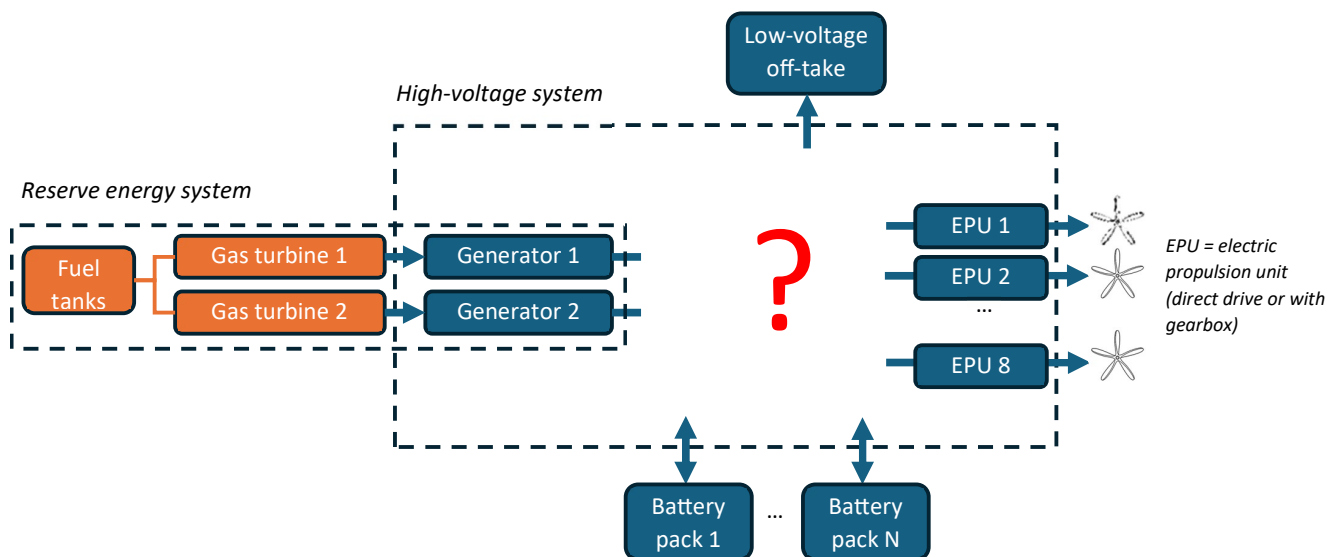

Figure 1: Notional drawing of the powertrain, kerosene part is only used for reserves (contingency, loiter, diversion) never for nominal mission.